













MALZEMELER

FITTINGS

KOD / CODE

											
3,5 x 16	6 mm	6 x 50	4 mm	M6 x 44	MİTİNGO ALÇAN CIVATA	M4 x 20	Ø8 x 30				
A1 x 50	x1	A4 x 8	A5 x 1	A6 x 18	x4	A22 x 2	B2 x 18	C2 x 22	C3 x 6	C8 x 18	E27 2 TK
											x6
											x4

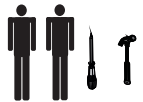
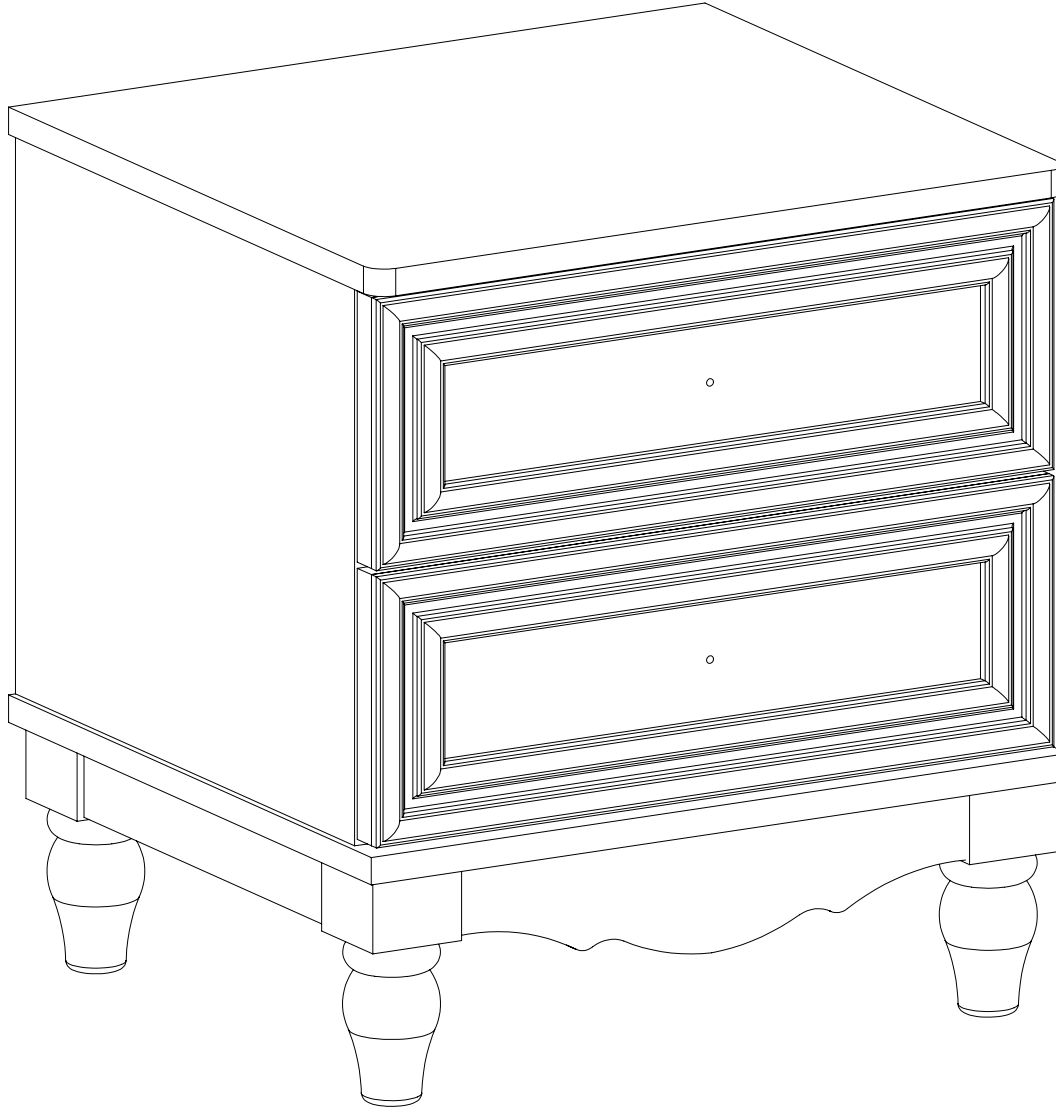

- Yedek malzeme isteklerinizi şemadaki kod ile belirtiniz.
- İLERİDE BAŞVURMAK İÇİN SAKLAYINIZ.

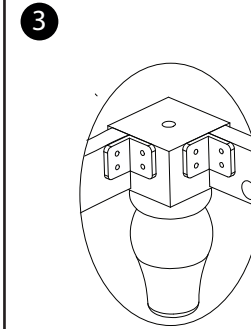
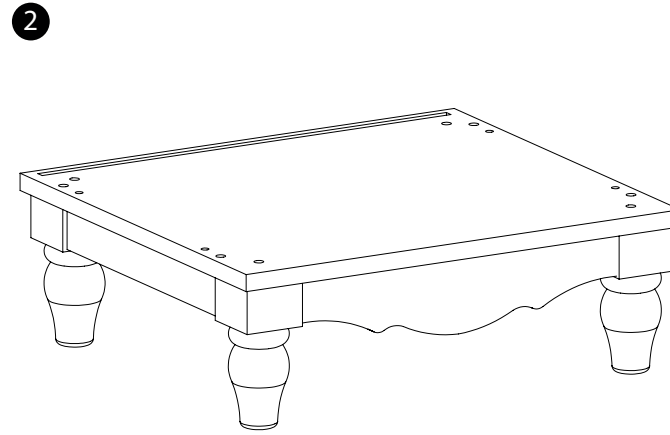
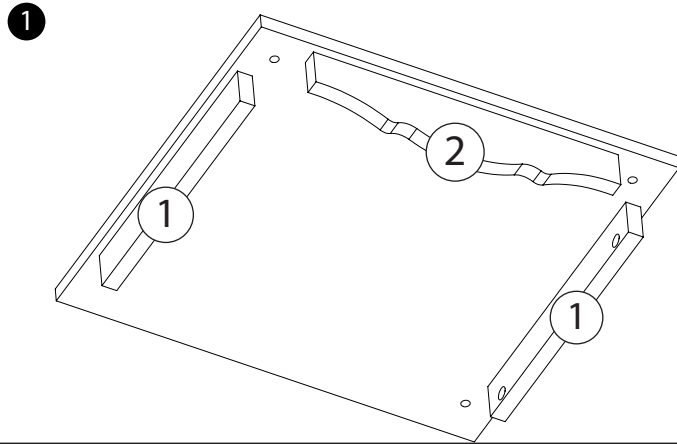

AYAK L BAĞLANTI SİSTEMİ

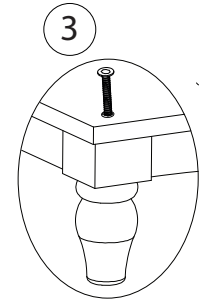

M10*40 HAVŞALI ALYAN CIVATA

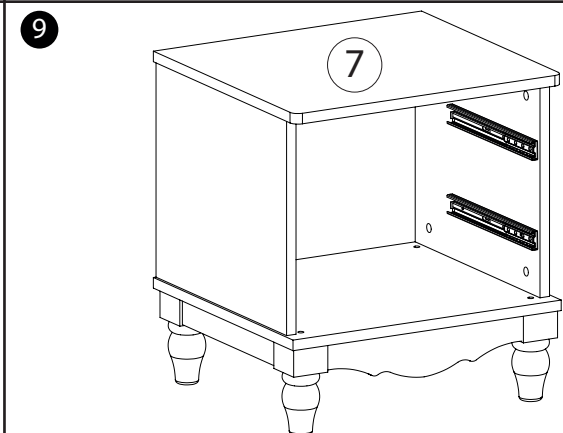
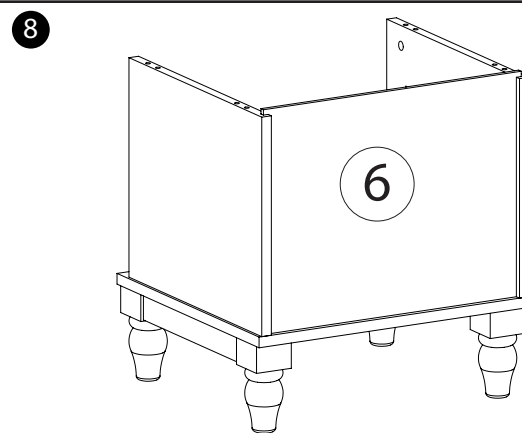
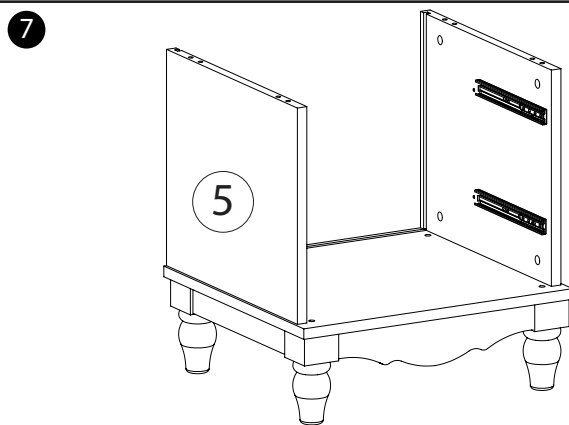
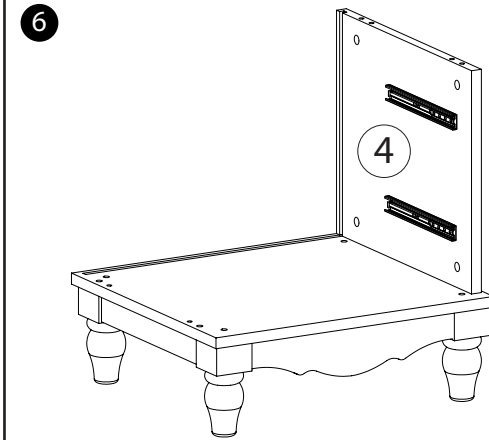
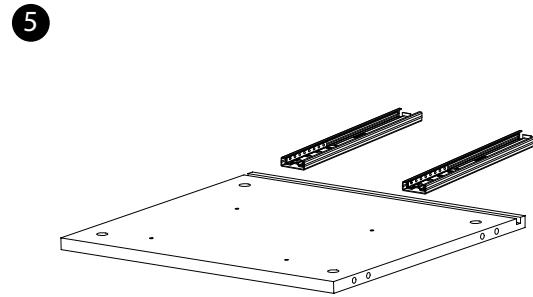
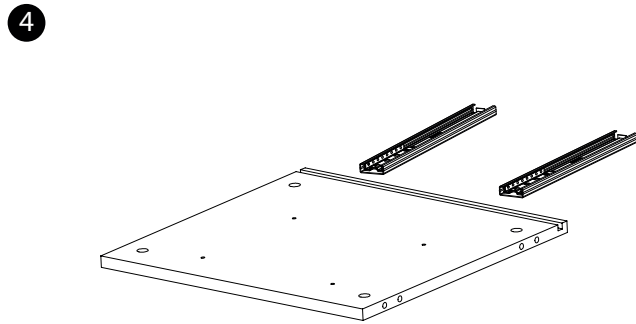

- Yedek malzeme isteklerinizi şemadaki kod ile belirtiniz.
- İLERİDE BAŞVURMAK İÇİN SAKLAYINIZ.



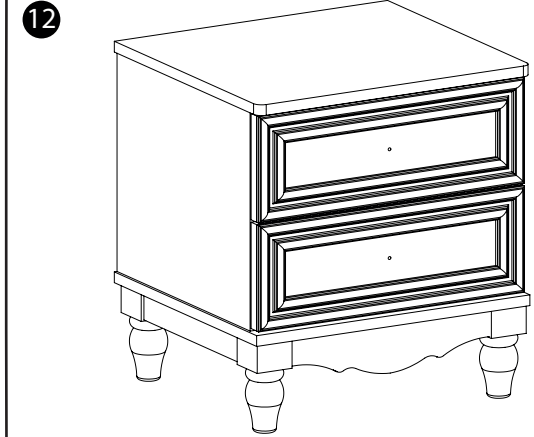
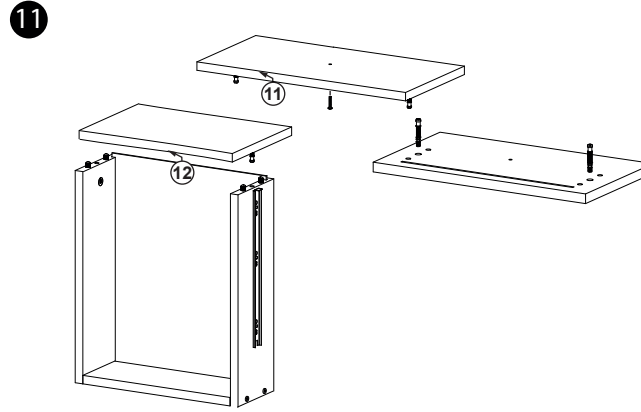
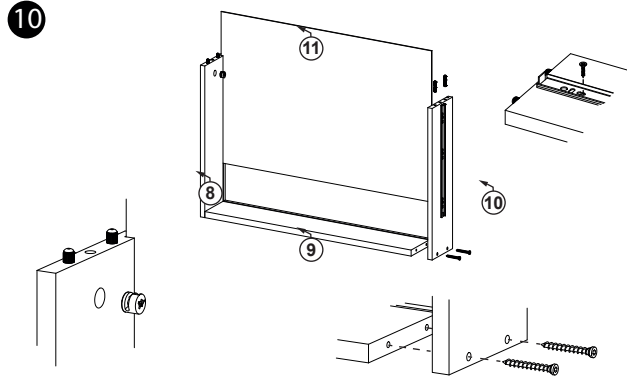

DİKKAT !!!!!

ÜRÜN MONTAJI YAPILIRKEN

ÜRÜNÜN SABİT KALACAGI YERE YAKIN BİR YERDE KURULMALIDIR

ÜRÜN KURULU DURUMDA BEREĞİNDEN FAZLA İTME VE SÜRÜKLEYEREK

TAŐIMA YAPMAYINIZ

- Yedek malzeme isteklerinizi Őemadaki kod ile belirtiniz.
- İLERİDE BAŐVURMAK İÇİN SAKLAYINIZ.

